

swissauto[®] ***EFI*** ***250***

Installation guide

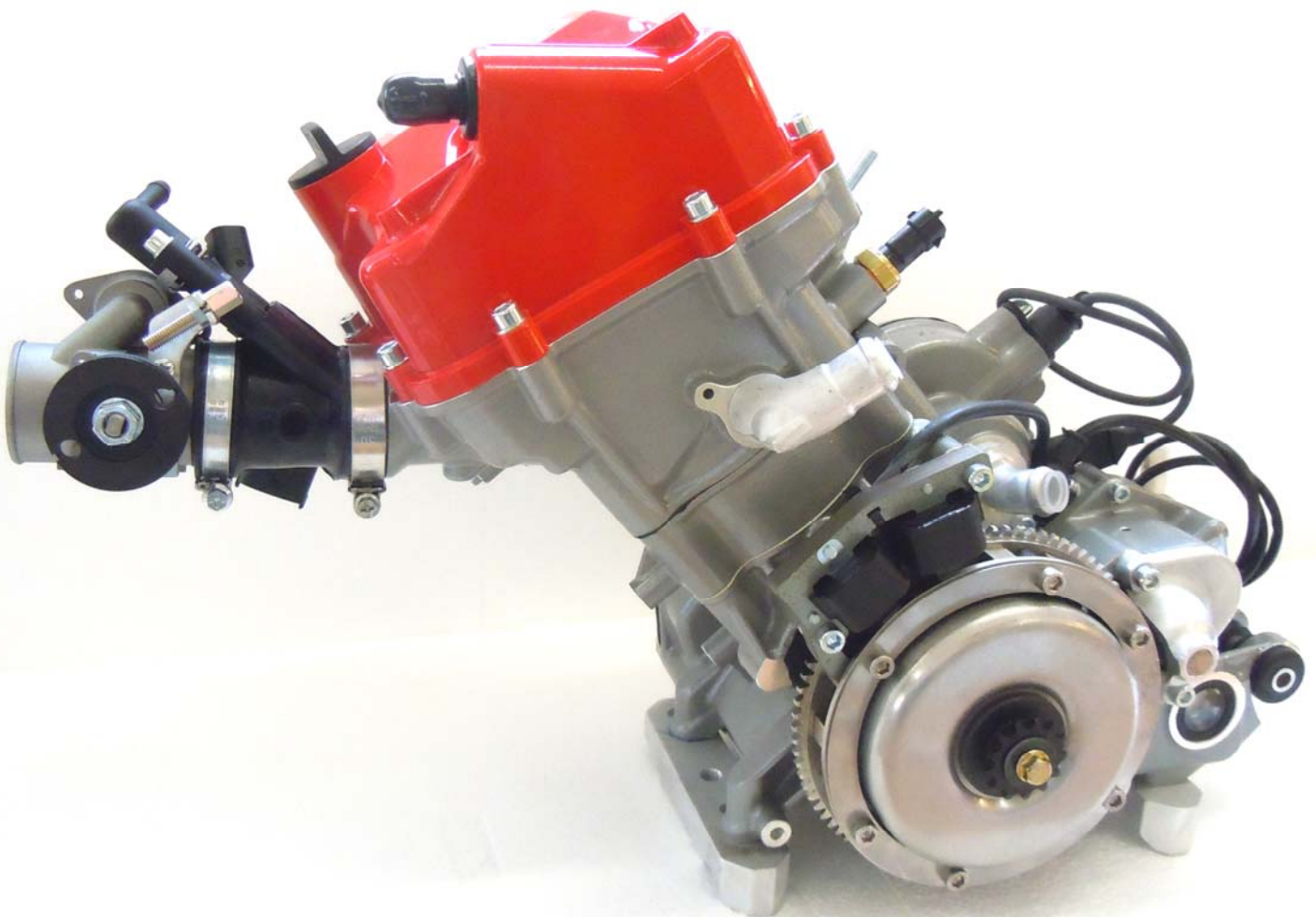

Can only be used on EVO2 engines

EFI kit installation guide

Scope of supply

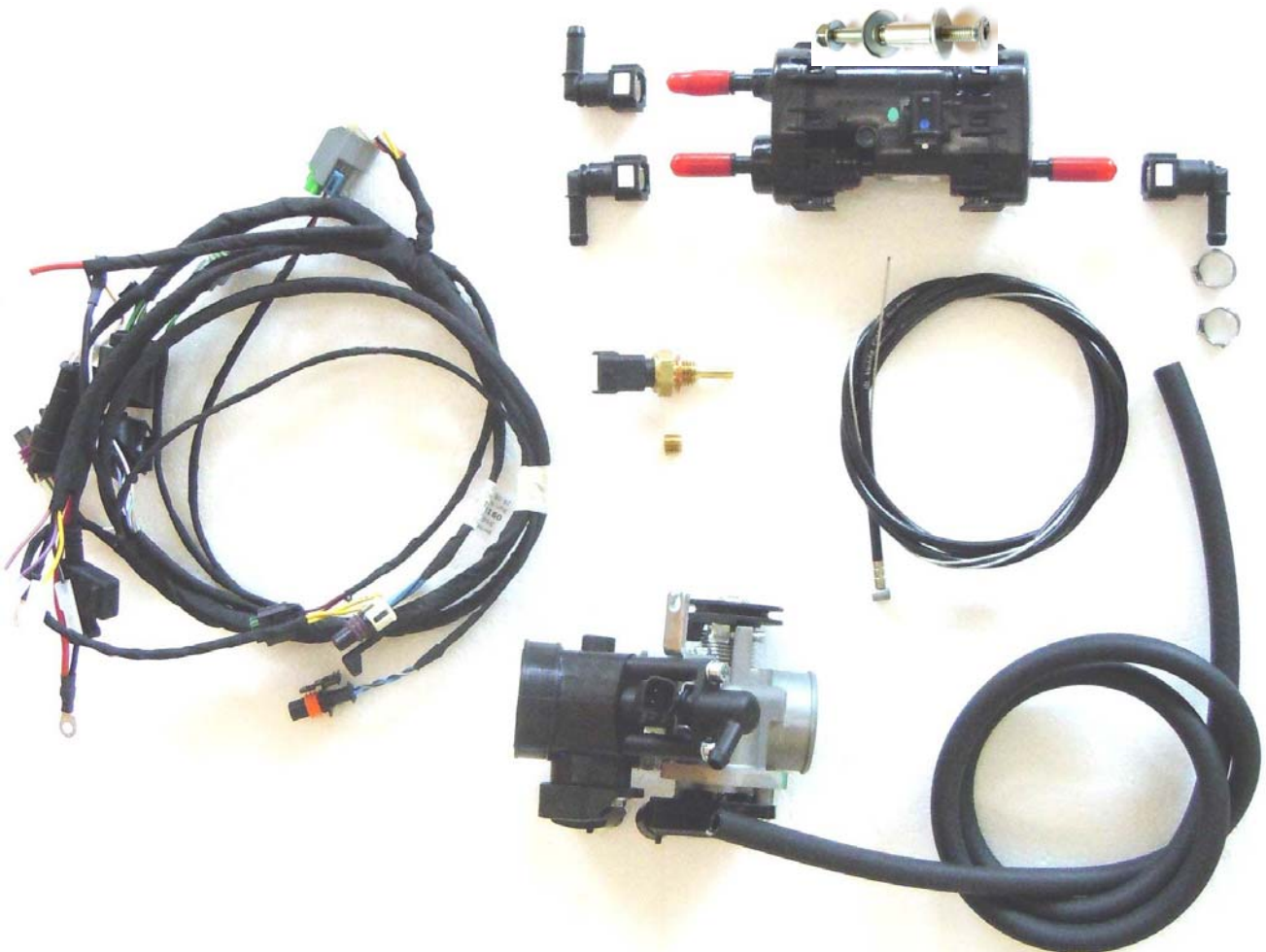

- Throttle body (incl. rubber, injector and sensors)
- Electronic fuel pump
- Mounting set fuel pump
- 3 Fast connectors fuel pump
- 2 clamps for pressure fuel hose
- Pressure fuel hose
- Throttle cable
- Water temperature sensor
- Plug for closing hose nipple tread
- Engine wire harness EFI
- **NO ECU!** The carb. ECU will be reprogrammed or exchanged by the dealer!

EFI kit installation guide



Remove hose nipple

Remove the Dellorto fuel pump



Close the hole with the screw plug
Use Loctite 577

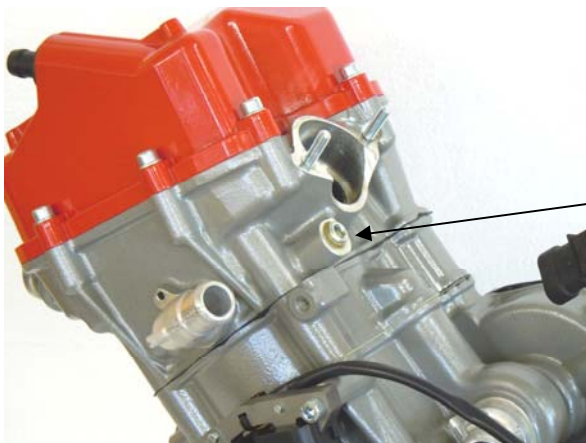

Remove the screw plug in the cylinder head.

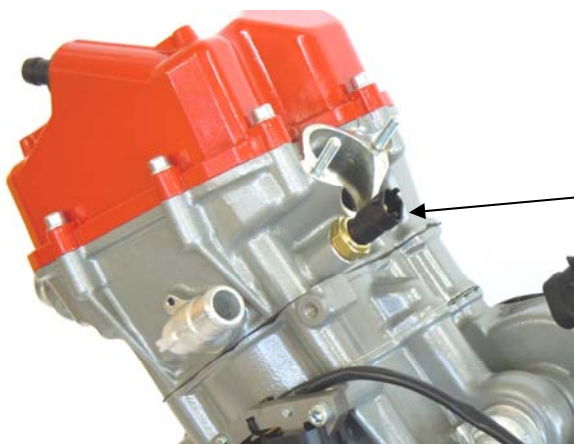

Install the water temperature sensor.

EFI kit installation guide



Remove the complete EVO2 carb wire harness.

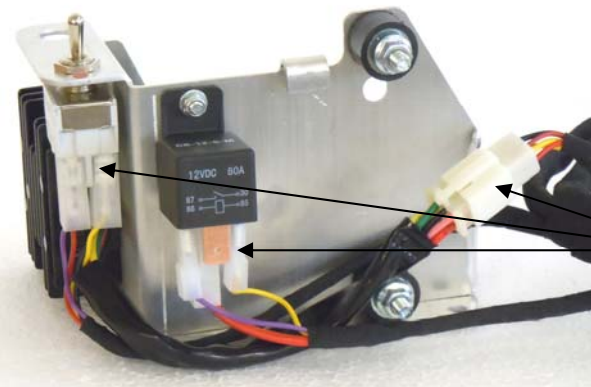

Install the EFI wire harness.

Connect the start/stop switch, the starter relay and the voltage regulator to the EFI wire harness.



Important!
Connect the wire harness correctly as shown to the start/stop switch. Else the engine will not start.

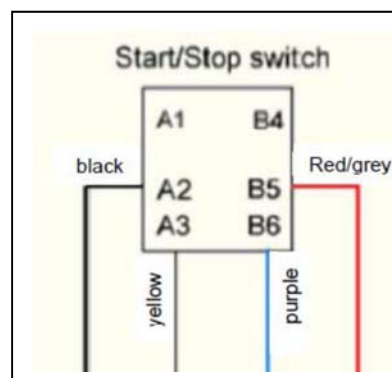

EFI kit installation guide



Install the reprogrammed or exchanged EFI ECU.
Connect the ECU to the wire harness.
Connect the starter cable to the starter relays.

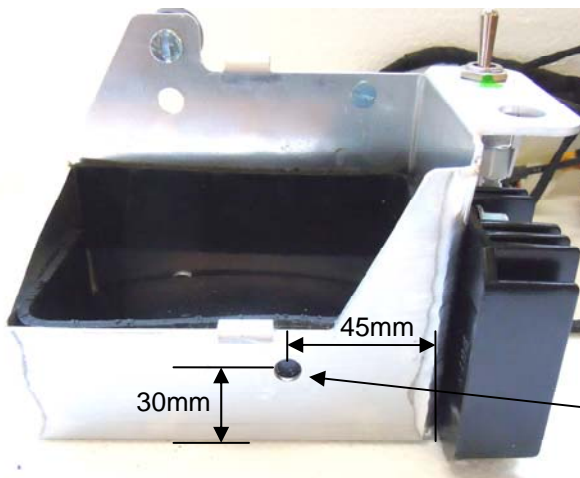

Electronic fuel pump installation.

Drill an 8mm hole.



Use the fuel pump mounting kit.

- Countersunk screw M6x70
- Sleeve 10x6x19 mm
- 2x washer 6x20x1,5 mm
- Nylon lock nut M6

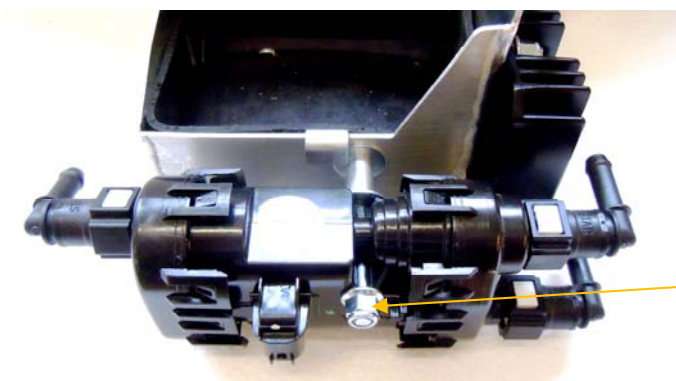

Install the electronic fuel pump as shown! The pump is only working in that position!

Tighten with max. 5Nm!
Else the pump gets damaged!

EFI kit installation guide

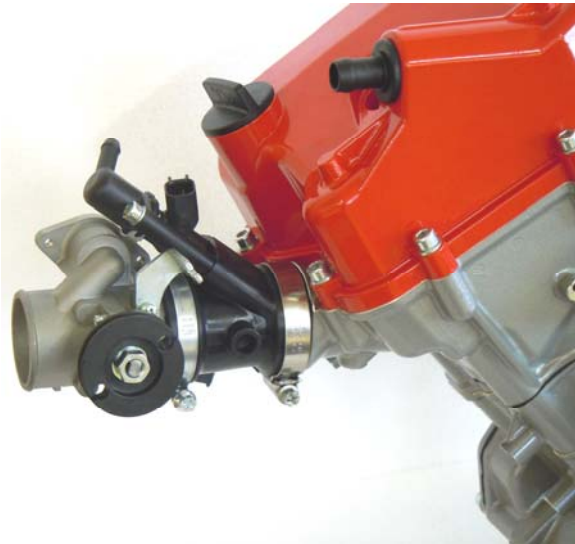

Push the throttle body on the intake port and tighten the clamp. (Use the clamp from the carb rubber)

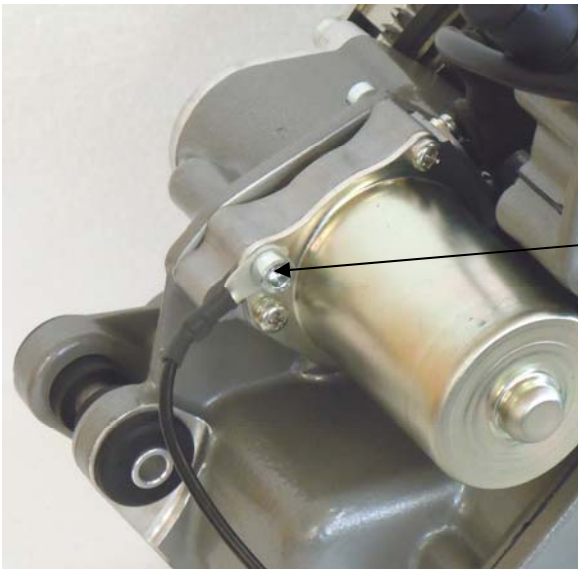

Connect the engine ground cable to the engine

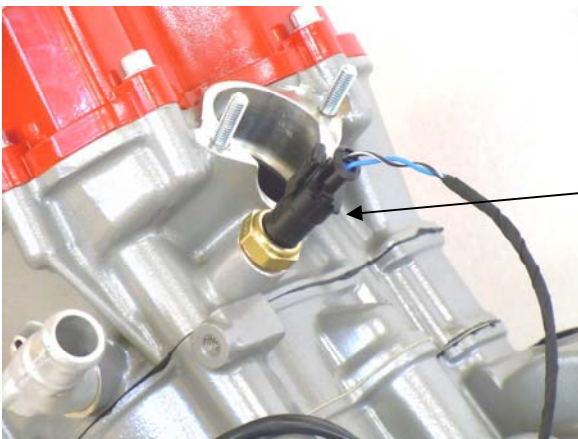

Connect the water temperature sensor.



Connect the crank trigger sensor.

EFI kit installation guide

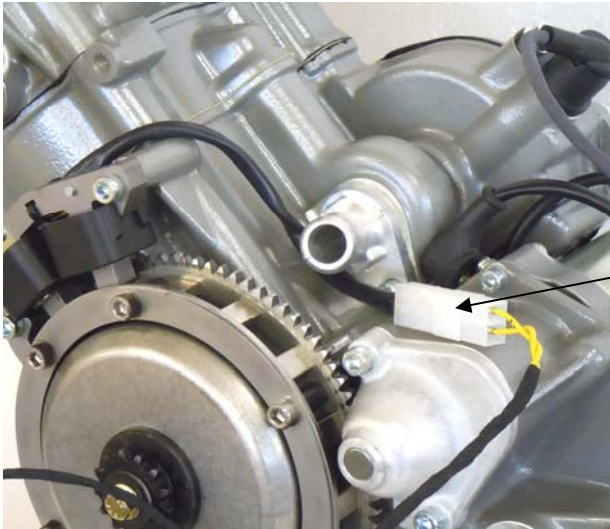

Connect the generator stator to the wire harness.

It's absolutely necessary to have a full equipped generator with all 16 magnets.

(In other way the battery will be discharged immediately and the engine will stop!)



Connect the injector nozzle, throttle position sensor, MAP sensor and the ignition coil.



Connect the battery.

(Don't add electrical attribute to the battery, the EFI needs full battery power during driving)

For fuel pump bleeding instruction please watch the video on YouTube!

http://www.youtube.com/watch?v=d_YtuKEqzwo

Search on youtube: swissauto250 EFI fuel pump instructions